



Machine Learning in Production

Toward Architecture and
Design

After requirements...

Fundamentals of Engineering AI-Enabled Systems

Holistic system view: AI and non-AI components, pipelines, stakeholders, environment interactions, feedback loops

Requirements:

- System and model goals
- User requirements
- Environment assumptions
- Quality beyond accuracy
- Measurement
- Risk analysis
- Planning for mistakes

Architecture + design:

- Modeling tradeoffs
- Deployment architecture
- Data science pipelines
- Telemetry, monitoring
- Anticipating evolution
- Big data processing
- Human-AI design

Quality assurance:

- Model testing
- Data quality
- QA automation
- Testing in production
- Infrastructure quality
- Debugging

Operations:

- Continuous deployment
- Contin. experimentation
- Configuration mgmt.
- Monitoring
- Versioning
- Big data
- DevOps, MLOps

Teams and process: Data science vs software eng. workflows, interdisciplinary teams, collaboration points, technical debt

Responsible AI Engineering

Provenance,
versioning,
reproducibility

Safety

Security and
privacy

Fairness

Interpretability
and explainability

Transparency
and trust

Ethics, governance, regulation, compliance, organizational culture

Learning Goals

- Describe the role of architecture and design between requirements and implementation
- Identify the different ML components and organize and prioritize their quality concerns for a given project
- Explain the key ideas behind decision trees and random forests and analyze consequences for various qualities
- Demonstrate an understanding of the key ideas of deep learning and how it drives qualities
- Plan and execute an evaluation of the qualities of alternative AI components for a given purpose

Readings

Required reading: Hulten, Geoff. "Building Intelligent Systems: A Guide to Machine Learning Engineering." (2018), Chapters 17 and 18

Recommended reading: Siebert, Julien, Lisa Joeckel, Jens Heidrich, Koji Nakamichi, Kyoko Ohashi, Isao Namba, Rieko Yamamoto, and Mikio Aoyama. "Towards Guidelines for Assessing Qualities of Machine Learning Systems." In International Conference on the Quality of Information and Communications Technology, pp. 17–31. Springer, Cham, 2020.

Recall: ML is a Component
in a System in an
Environment

Recall: Systems Thinking

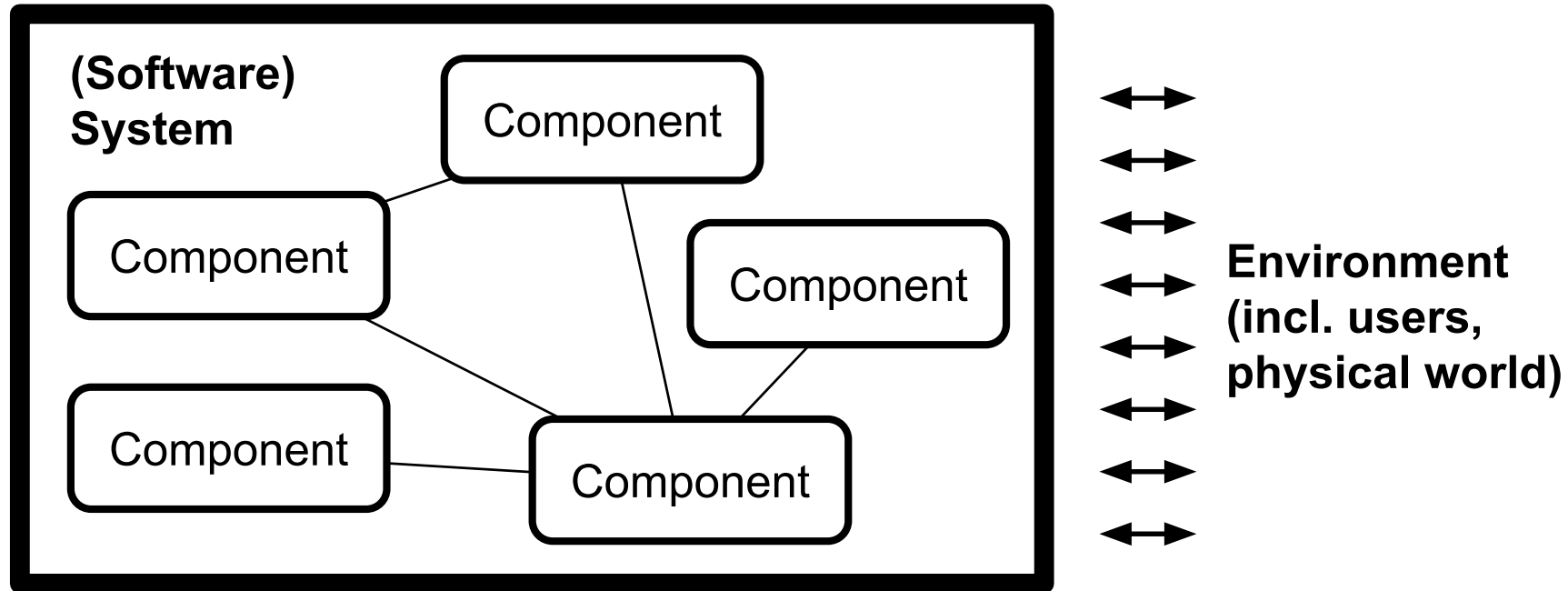

A system is a set of inter-related components that work together in a particular environment to perform whatever functions are required to achieve the system's objective -- Donella Meadows

Thinking like a Software Architect



From Requirements to Implementations...

We know what to build, but how? How to we meet the quality goals?



Software architecture: Key design decisions, made early in the development, focusing on key product qualities

Architectural decisions are hard to change later

Architecture Decisions: Examples

- What are the major components in the system? What does each component do?
- Where do the components live? Monolithic vs microservices?
- How do components communicate to each other? Synchronous vs asynchronous calls?
- What API does each component publish? Who can access this API?
- Where does the ML inference happen? Client-side or server-side?
- Where is the telemetry data collected from the users stored?
- How large should the user database be? Centralized vs decentralized?
- ...and many others

Software Architecture

*Architecture represents the set of **significant design** decisions that shape the form and the function of a system, where **significant** is measured by cost of change. -- [Grady Booch, 2006]*

How much Architecture/Design?

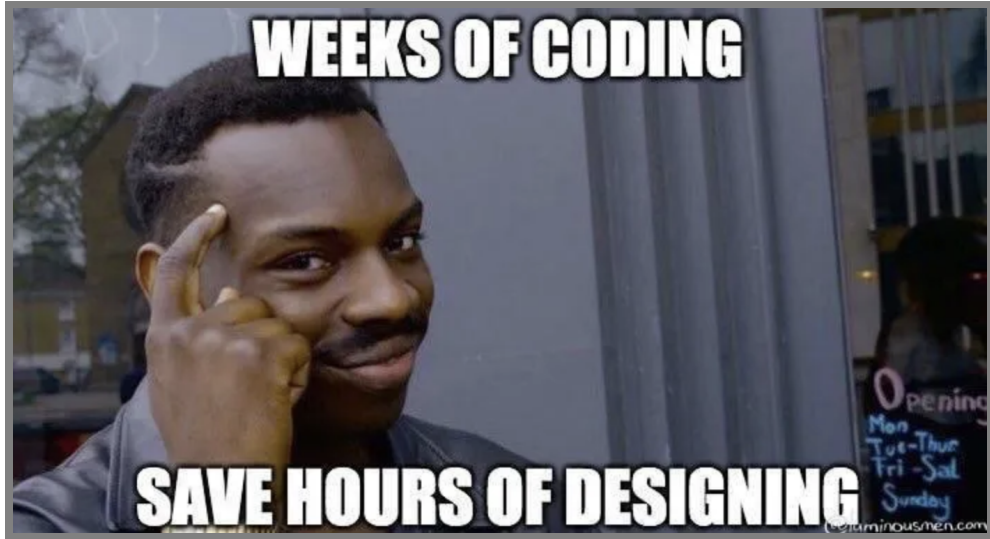

Software Engineering Theme: *Think before you code*

Like requirements: Slower initially, but upfront investment can prevent problems later and save overall costs

-> Focus on most important qualities early, but leave flexibility

Why Architecture? (Kazman et al. 2012)

Represents earliest design decisions.

Aids in **communication** with stakeholders: Shows them “how” at a level they can understand, raising questions about whether it meets their needs

Defines **constraints** on implementation: Design decisions form “load-bearing walls” of application

Dictates **organizational structure**: Teams work on different components

Inhibits or enables **quality attributes**: Similar to design patterns

Supports **predicting** cost, quality, and schedule: Typically by predicting information for each component

Aids in software **evolution**: Reason about cost, design, and effect of changes

Quality Requirements Drive Architecture Design

Driven by requirements, identify most important qualities

Examples:

- Development cost, operational cost, time to release
- Scalability, availability, response time, throughput
- Security, safety, usability, fairness
- Ease of modifications and updates
- ML: Accuracy, ability to collect data, training latency

Architecture Design Involves Quality Trade-offs

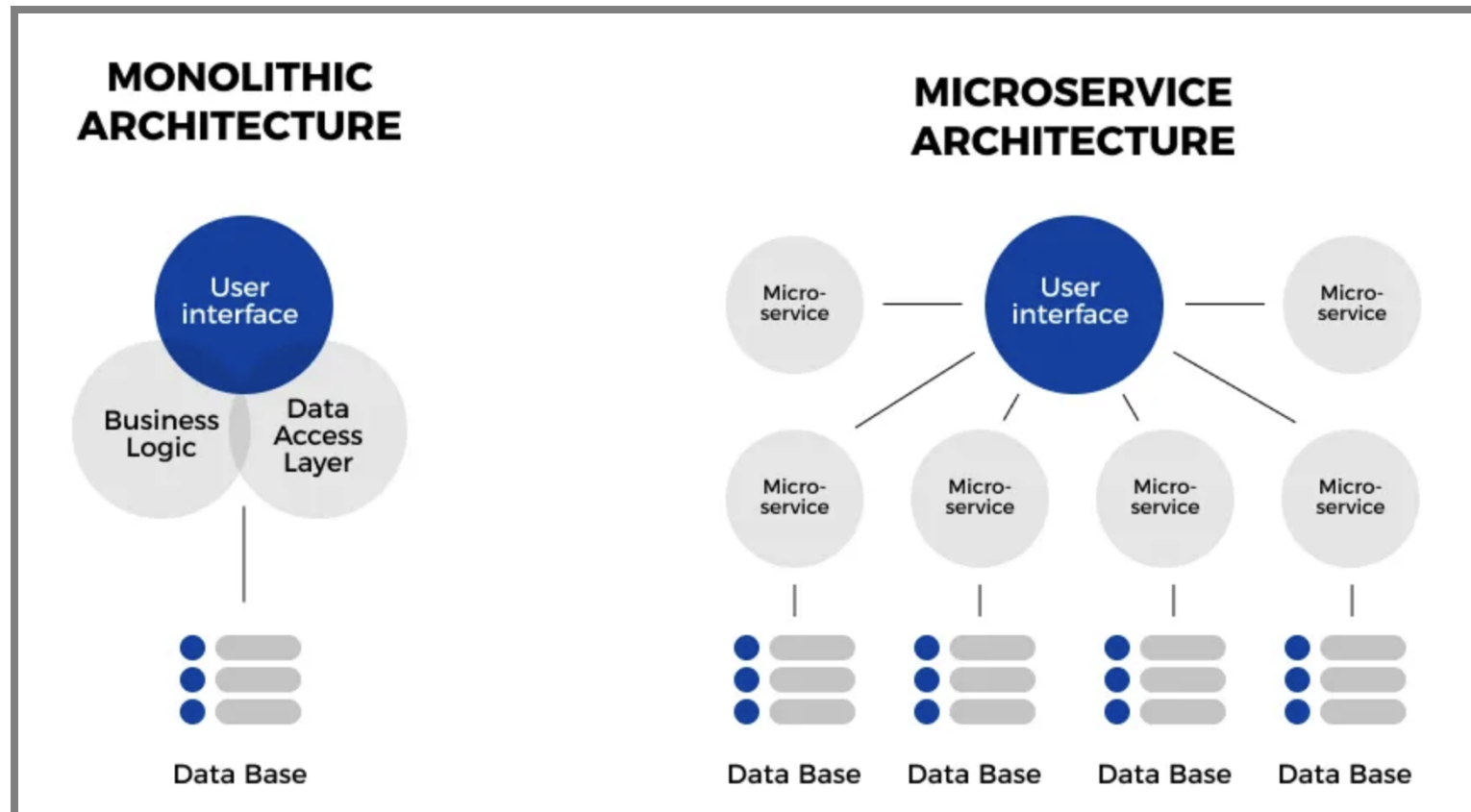

≡ Q. What are quality trade-offs between the two?

Codifying Design Knowledge

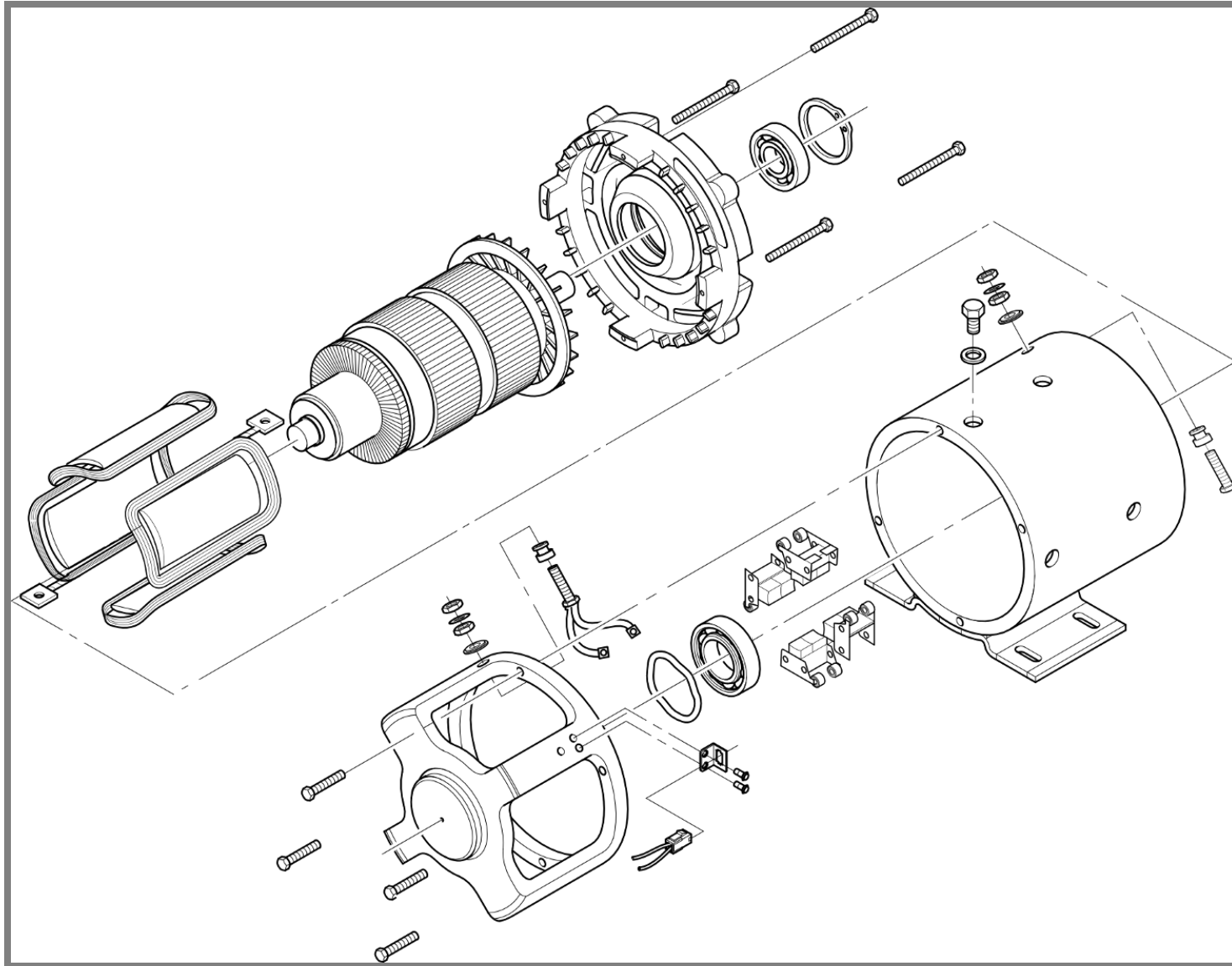

Common Components in ML-based Systems

- **Model inference service:** Uses model to make predictions for input data
- **ML pipeline:** Infrastructure to train/update the model
- **Monitoring:** Observe model and system
- **Data sources:** Manual/crowdsourcing/logs/telemetry/...
- **Data management:** Storage and processing of data, often at scale
- **Feature store:** Reusable feature engineering code, cached feature computations

Common System-Wide Design Challenges

Separating concerns, understanding interdependencies

- e.g., anticipating/breaking feedback loops, conflicting needs of components

Facilitating experimentation, updates with confidence

Separating training and inference; closing the loop

- e.g., collecting telemetry to learn from user interactions

Learn, serve, and observe at scale or with resource limits

- e.g., cloud deployment, embedded devices

Each system is different...

the-changelog-318 Last saved a few seconds ago ... Share

[← Dashboard](#) | **Quality:** High ⓘ

00:00  Offset 00:00 01:31:27

▶ Play ↺ Back 5s 1x Speed 🔊 Volume

NOTES
Write your notes here

Speaker 5 ▶ 07:44

Yeah. So there's a slight story behind that. So back when I was in, uh, Undergrad, I wrote a program for myself to measure a, the amount of time I did data entry from my father's business and I was on windows at the time and there wasn't a function called time dot [inaudible] time, uh, which I needed to parse dates to get back to time, top of representation, uh, I figured out a way to do it and I gave it to what's called the python cookbook because it just seemed like something other people could use. So it was just trying to be helpful. Uh, subsequently I had to figure out how to make it work because I didn't really have to. Basically, it bothered me that you had to input all the locale information and I figured out how to do it over the subsequent months. And actually as a graduation gift from my Undergrad, the week following, I solved it and wrote it all out.

Speaker 5 ▶ 08:38

And I asked, uh, Alex Martelli, the editor of the Python Cookbook, which had published my original recipe, a, how do I get this into python? I think it might help

How did we do on your transcript? ★★★★★

Each system is different...

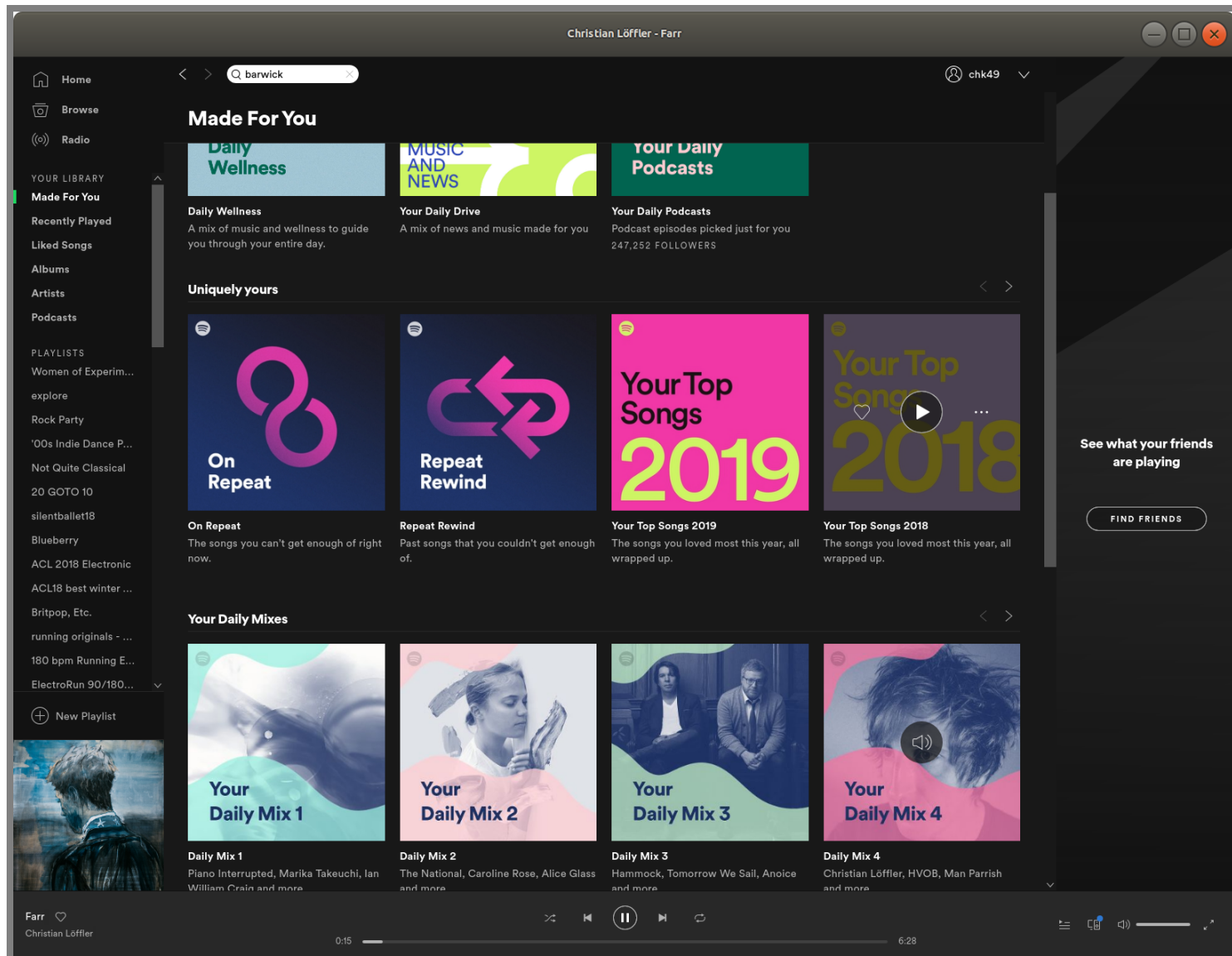

Each system is different...



Each system is different...

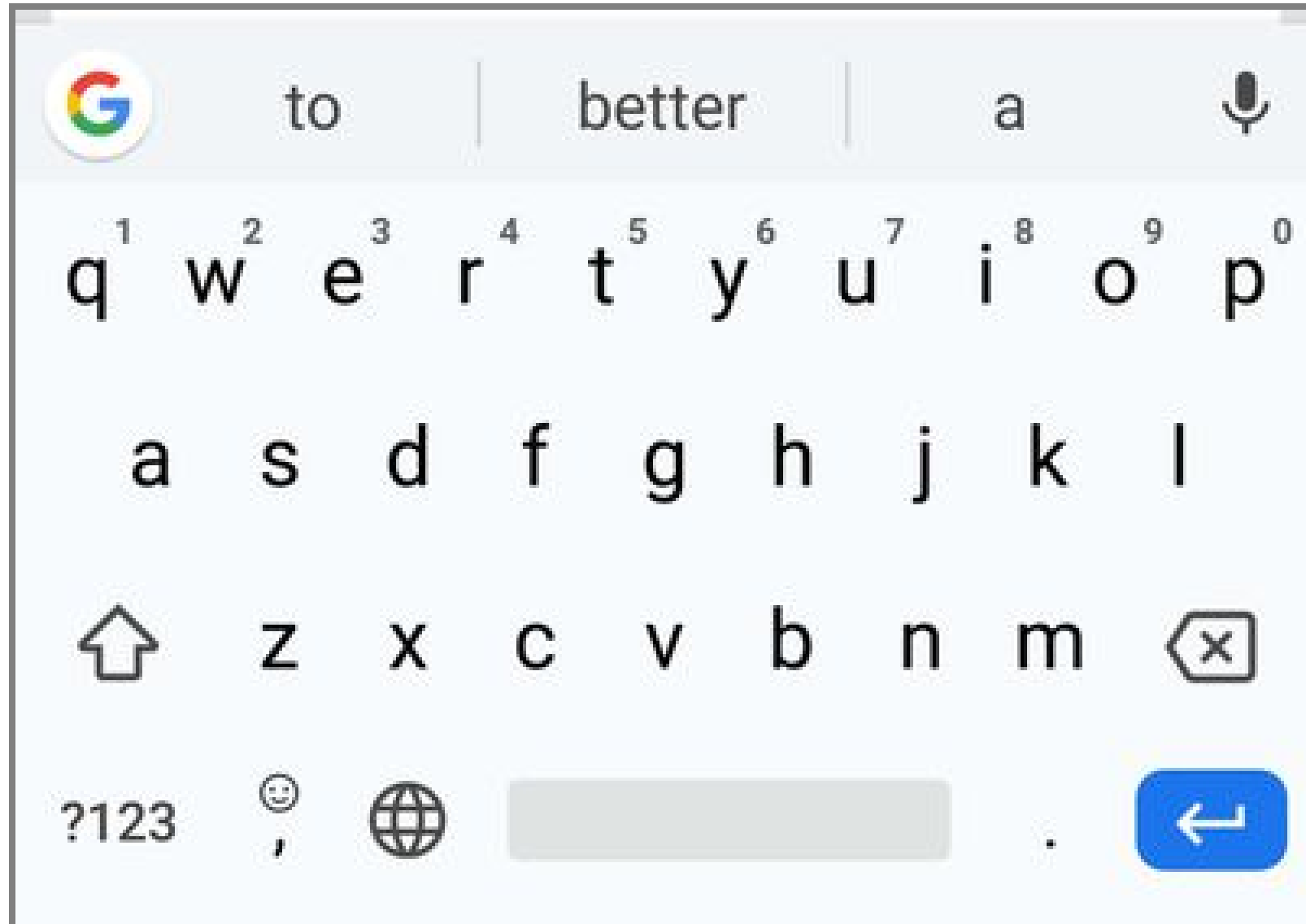

System Decomposition

Each system is different, identify important components

Examples:

- Personalized music recommendations: microservice deployment in cloud, logging of user activity, nightly batch processing for inference, regular model updates, regular experimentation, easy fallback
- Transcription service: irregular user interactions, large model, expensive inference, inference latency not critical, rare model updates
- Autonomous vehicle: on-board hardware sets limits, real-time needs, safety critical, updates necessary, limited experimentation in practice, not always online
- Smart keyboard: privacy focused, small model, federated learning on user device, limited telemetry

Scoping Relevant Qualities of ML Components

From System Quality Requirements to Component Quality Specifications

Design Decision: ML Model Selection

How do I decide which ML algorithm to use for my project?

Criteria: Quality Attributes & Constraints

Accuracy is not Everything

Beyond prediction accuracy, what qualities may be relevant for an ML component?



Speaker notes

Collect qualities on whiteboard



Qualities of Interest?

Scenario: ML component for transcribing audio files

the-changelog-318
← Dashboard | Quality: High ⓘ

Last saved a few seconds ago ... Share

00:00 🔊 Offset 00:00 01:31:27

Play Back 5s 1x Speed Volume

NOTES
Write your notes here

Speaker 5 ▶ 07:44

Yeah. So there's a slight story behind that. So back when I was in, **uh**, Undergrad, I wrote a program for myself to measure a, **the** amount of time I did data entry **from** my father's business and I was on windows at the time and there wasn't a function called time dot **[inaudible]** time, **uh**, which I **needed** to parse dates to get back to time, **top** of representation, **uh**, I figured out a way to do it and I gave it to what's called the python cookbook because it just seemed like something other people could use. So **it was** just trying to be helpful. **Uh**, subsequently I had to figure out how to make it work **because** I didn't really have to. Basically, it bothered me that you had to input all the **locale** information and I figured out how to do it over **the subsequent months**. And actually as a graduation gift from my Undergrad, the week following, I solved it and wrote it all out.

Speaker 5 ▶ 08:38

And I asked, **uh**, Alex Martelli, the editor of the Python Cookbook, which had published my original recipe, **a**, how do I get this into python? I think **it** might help

How did we do on your transcript? ☆☆☆☆☆

Speaker notes

Which of the previously discussed qualities are relevant? Which additional qualities may be relevant here?

Cost per transaction; how much does it cost to transcribe? How much do we make?



Qualities of Interest?

Scenario: Component for detecting lane markings in a vehicle

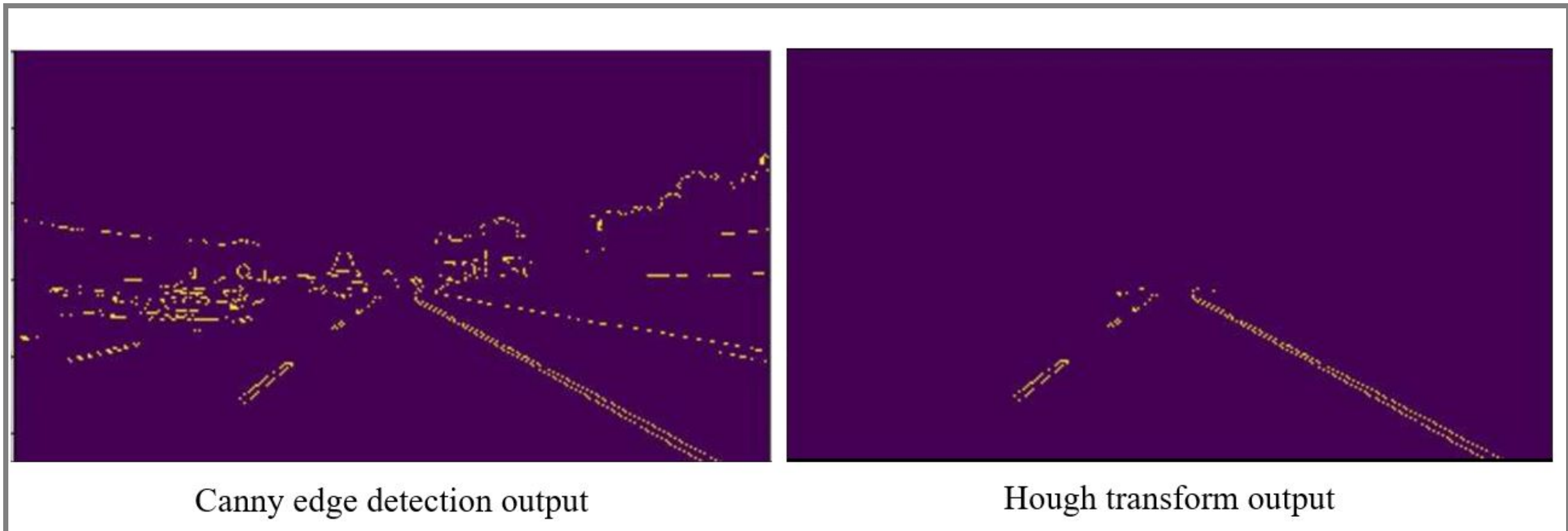

Speaker notes

Which of the previously discussed qualities are relevant? Which additional qualities may be relevant here?

Realtime use



Qualities of Interest?

Scenario: Component for detecting credit card frauds, as a service for banks

Speaker notes

Very high volume of transactions, low cost per transaction, frequent updates

Incrementality



Common ML Qualities to Consider

- Accuracy
- Correctness guarantees? Probabilistic guarantees (--> symbolic AI)
- How many features?
- How much data needed? Data quality important?
- Incremental training possible?
- Training time, memory need, model size -- depending on training data volume and feature size
- Inference time, energy efficiency, resources needed, scalability
- Interpretability, explainability
- Robustness, reproducibility, stability
- Security, privacy, fairness

Constraints and Tradeoffs

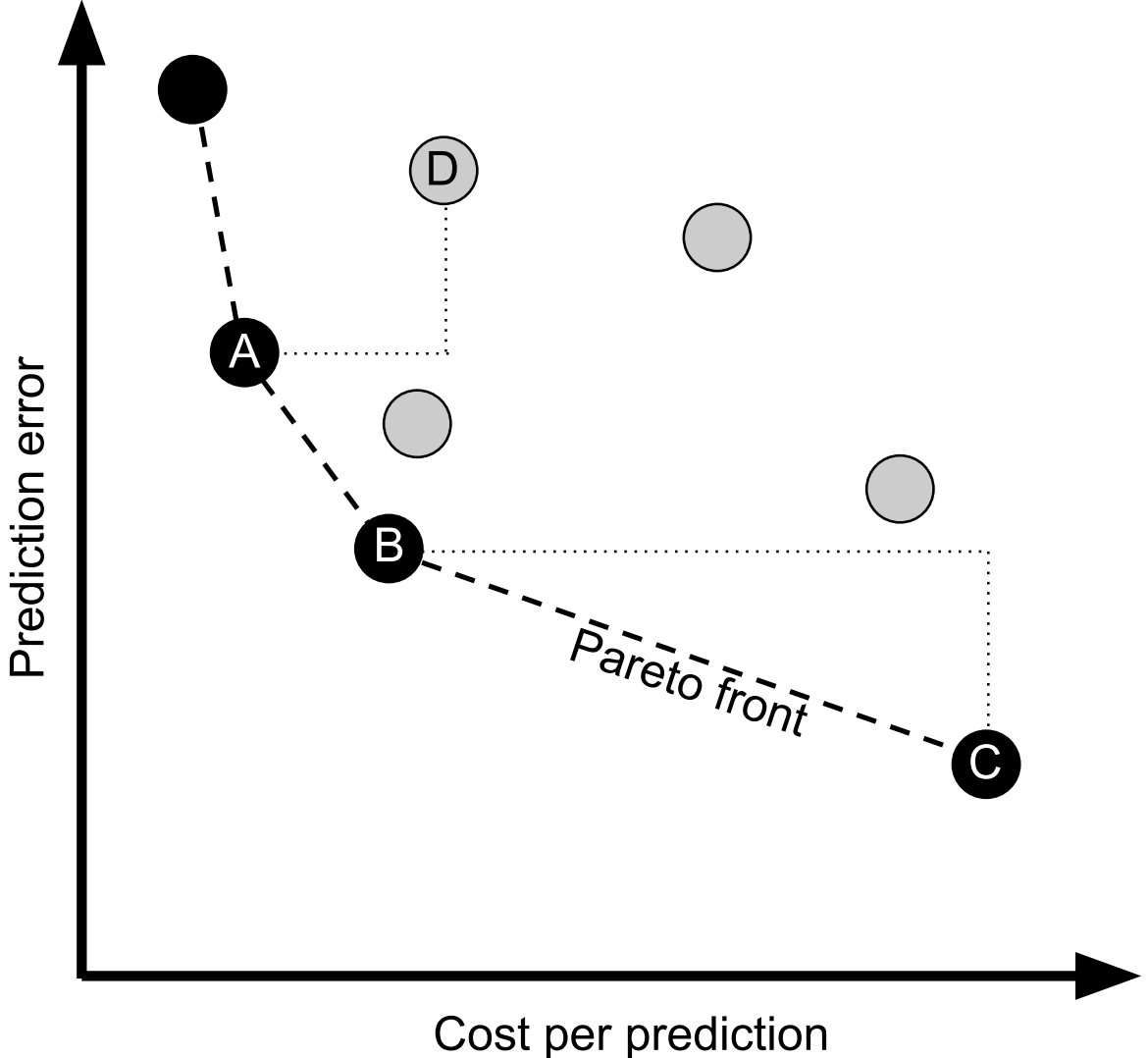

Speaker notes

How do I decide which ML algorithm to use for my project?

Criteria: Quality Attributes & Constraints



Constraints

Constraints define the space of attributes for valid design solutions

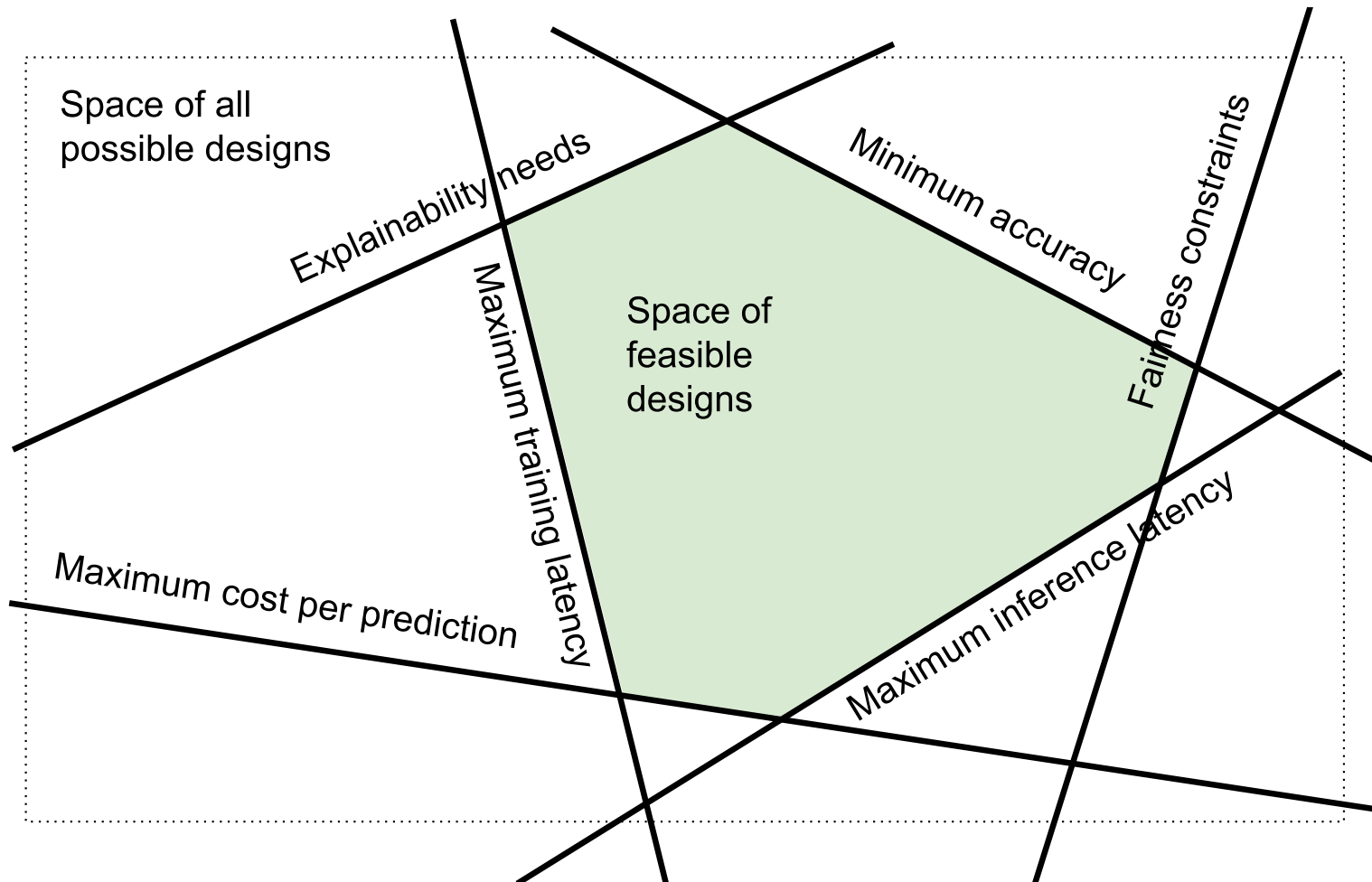

Design space exploration: The space of all possible designs (dotted rectangle) is reduced by several constraints on qualities of the system, leaving only a subset of designs for further consideration (highlighted center area).

Types of Constraints

Problem constraints: Minimum required QAs for an acceptable product

Project constraints: Deadline, project budget, available personnel/skills

Design constraints

- Type of ML task required (regression/classification)
- Available data
- Limits on computing resources, max. inference cost/time

Constraints: Cancer Prognosis?

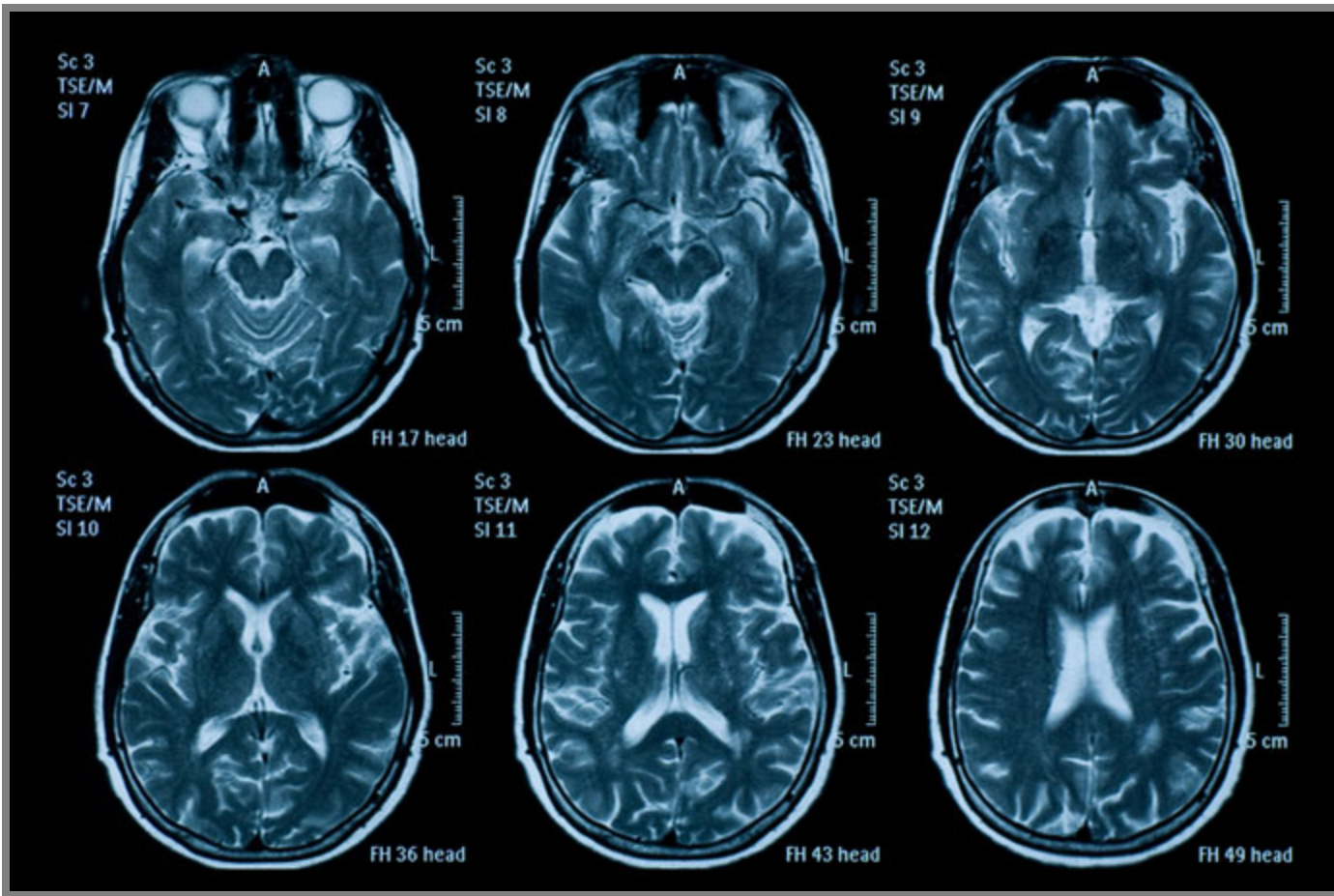

Constraints: Music Recommendations?

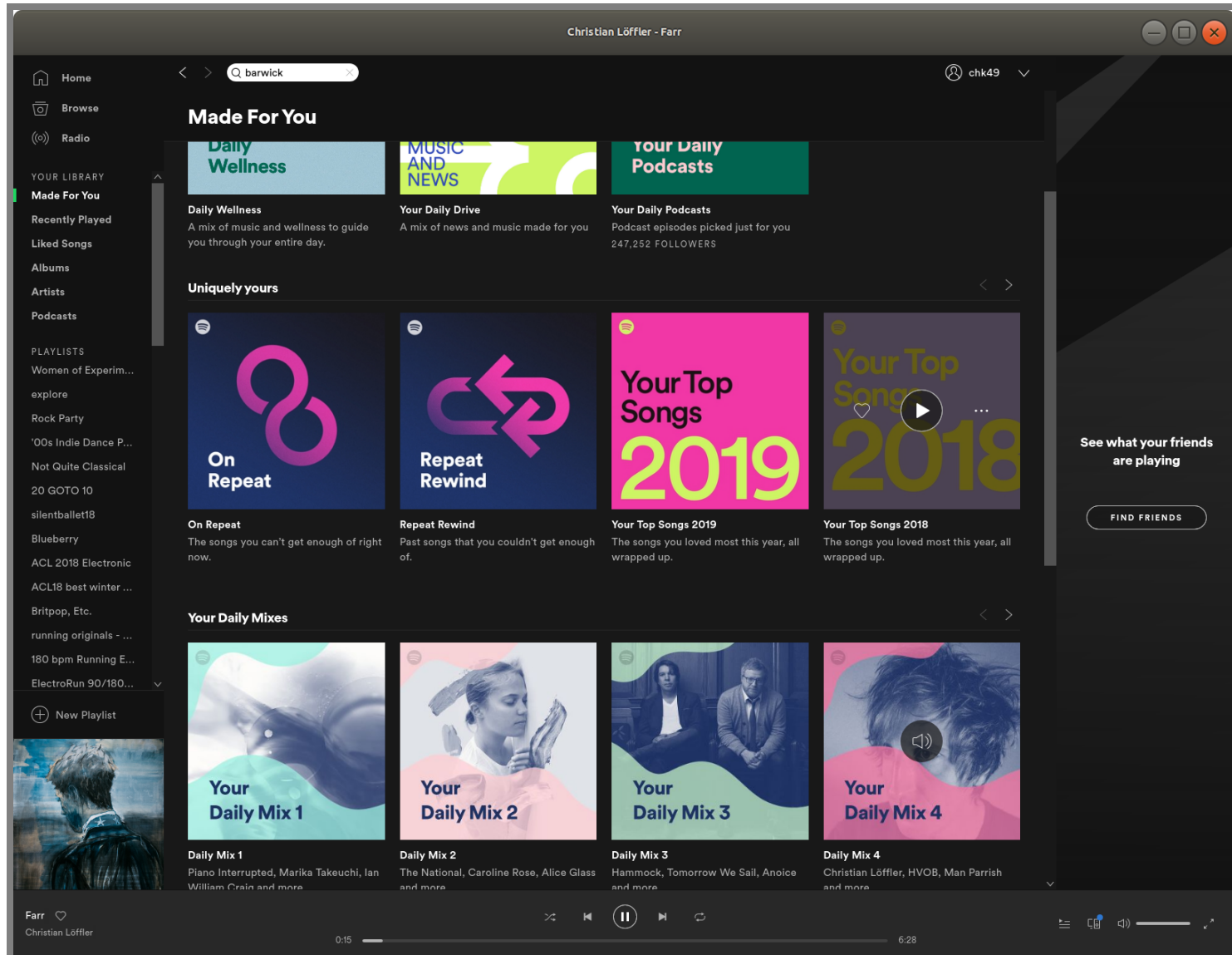

Trade-offs between ML algorithms

If there are multiple ML algorithms that satisfy the given constraints, which one do we select?

Different ML qualities may conflict with each other; this requires making a **trade-off** between these qualities

Among the qualities of interest, which one(s) do we care the most about?

- And which ML algorithm is most suitable for achieving those qualities?
- (Similar to requirements conflicts)

Trade-offs: Cost vs Accuracy

Netfli Prize

COMPLETED

Home Rules Leaderboard Update Download

Leaderboard

Showing Test Score. [Click here to show quiz score](#)

Display top leaders.

Rank	Team Name	Best Test Score	% Improvement	Best Submit Time
Grand Prize - RMSE = 0.8567 - Winning Team: BellKor's Pragmatic Chaos				
1	BellKor's Pragmatic Chaos	0.8567	10.06	2009-07-26 18:18:28
2	The Ensemble	0.8567	10.06	2009-07-26 18:38:22
3	Grand Prize Team	0.8582	9.90	2009-07-10 21:24:40
4	Opera Solutions and Vandelay United	0.8588	9.84	2009-07-10 01:12:31
5	Vandelay Industries!	0.8591	9.81	2009-07-10 00:32:20
6	PragmaticTheory	0.8594	9.77	2009-06-24 12:06:56
7	BellKor in BioChaos	0.8601	9.70	2009-05-13 08:14:09
8	Dace	0.8612	9.59	2009-07-24 17:18:43

"We evaluated some of the new methods offline but the additional accuracy gains that we measured did not seem to justify the engineering effort needed to bring them into a production environment."

Amatriain & Basilico. [Netflix Recommendations: Beyond the 5 stars](#), Netflix Technology Blog (2012)

Trade-offs: Accuracy vs Interpretability

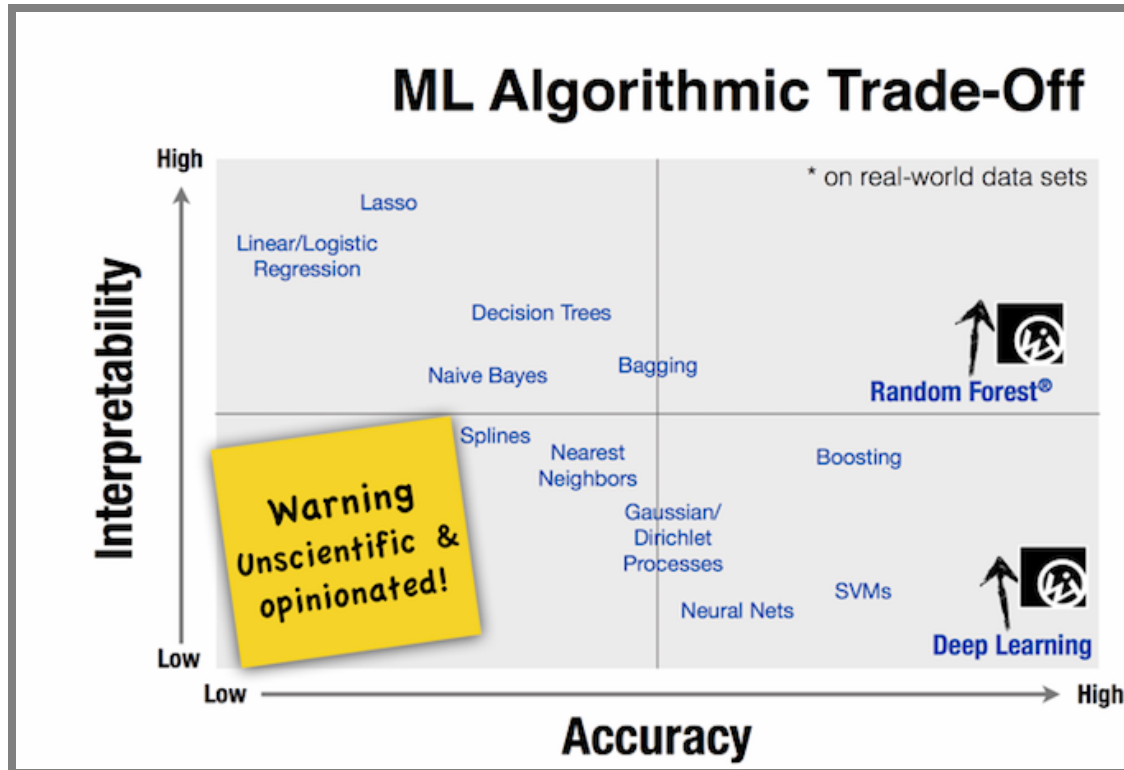

Q. Examples where one is more important than the other?

Bloom & Brink. [Overcoming the Barriers to Production-Ready Machine Learning Workflows](#), Presentation at O'Reilly Strata Conference (2014).

Network Size

- 50 Layer ResNet network -- classifying 224x224 images into 1000 categories
 - 26 million weights, computes 16 million activations during inference, 168 MB to store weights as floats
- Google in 2012(!): 1TB-1PB of training data, 1 billion to 1 trillion parameters
- OpenAI's GPT-2 (2019) -- text generation
 - 48 layers, 1.5 billion weights (~12 GB to store weights)
 - released model reduced to 117 million weights
 - trained on 7-8 GPUs for 1 month with 40GB of internet text from 8 million web pages
- OpenAI's GPT-3 (2020): 96 layers, 175 billion weights, 700 GB in memory, \$4.6M in approximate compute cost for training

Speaker notes

<https://lambdalabs.com/blog/demystifying-gpt-3/>



Cost & Energy Consumption

Consumption	CO2 (lbs)	Training one model (GPU)	CO2 (lbs)
Air travel, 1 passenger, NY↔SF	1984	NLP pipeline (parsing, SRL)	39
Human life, avg, 1 year	11,023	w/ tuning & experimentation	78,468
American life, avg, 1 year	36,156	Transformer (big)	192
Car, avg incl. fuel, 1 lifetime	126,000	w/ neural architecture search	626,155

Cost & Energy Consumption

Model	Hardware	Hours	CO2	Cloud cost in USD
Transformer	P100x8	84	192	289–981
ELMo	P100x3	336	262	433–1472
BERT	V100x64	79	1438	3751–13K
NAS	P100x8	274,120	626,155	943K–3.2M
GPT-2	TPUv3x32	168	—	13K–43K
GPT-3			—	4.6M

Strubell, Emma, Ananya Ganesh, and Andrew McCallum. "[Energy and Policy Considerations for Deep Learning in NLP](#)." In Proc. ACL, pp. 3645-3650. 2019.

Summary

Software architecture focuses on early key design decisions, focused on key qualities

Between requirements and implementation

Decomposing the system into components, many ML components

Many qualities of interest, define metrics and operationalize

Constraints and tradeoff analysis for selecting ML techniques in production ML settings

Further Readings

- Bass, Len, Paul Clements, and Rick Kazman. Software architecture in practice. Addison-Wesley Professional, 3rd edition, 2012.
- Yokoyama, Haruki. “Machine learning system architectural pattern for improving operational stability.” In 2019 IEEE International Conference on Software Architecture Companion (ICSA-C), pp. 267–274. IEEE, 2019.
- Serban, Alex, and Joost Visser. “An Empirical Study of Software Architecture for Machine Learning.” In Proceedings of the International Conference on Software Analysis, Evolution and Reengineering (SANER), 2022.
- Lakshmanan, Valliappa, Sara Robinson, and Michael Munn. Machine learning design patterns. O’Reilly Media, 2020.
- Lewis, Grace A., Ipek Ozkaya, and Xiwei Xu. “Software Architecture Challenges for ML Systems.” In 2021 IEEE International Conference on Software Maintenance and Evolution (ICSME), pp. 634–638. IEEE, 2021.
- Vogelsang, Andreas, and Markus Borg. “Requirements Engineering for Machine Learning: Perspectives from Data Scientists.” In Proc. of the 6th International Workshop on Artificial Intelligence for Requirements Engineering (AIRE), 2019.
- Habibullah, Khan Mohammad, Gregory Gay, and Jennifer Horkoff. "[Non-Functional Requirements for Machine Learning: An Exploration of System Scope and Interest.](#)" arXiv preprint arXiv:2203.11063 (2022).

